



Submersible slurry pumps



Slurry pumps:

- Bravo 200
- Bravo 300
- Bravo 400
- Bravo 500
- Bravo 600
- Bravo 700
- Bravo 800
- Bravo 900

60 Hz



Submersible slurry pumps for pumping fluids with abrasive solids

Pumping slurry is one of the most demanding applications for any pump. Parts wear out, maintenance and repair costs are high. In many cases, frequent pump failures lead to costly production downtime. Also, excessive sediment build-up in a sump costs time and money to remove.

With Grindex new slurry pump series, you have an effective solution to the rising costs of slurry handling: robust, hard-working pumps that lower operating and maintenance costs and offer excellent value in terms of initial investment.

Grindex, being a world leader in submersible pumps, has focused on solving these problems for years, developing slurry pumps that can handle the toughest, high-wear applications.

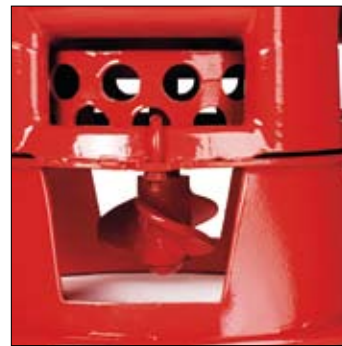

Why submersible?

The submersible concept offers numerous benefits over dry-mounted pumps. As it doesn't require any support superstructure, it requires less space for operation and is very easy to install. Being submersible means it's flood-proof. Operating underwater also means quiet operation. On top of that, the time for maintenance can be greatly reduced.

The Bravo pumps are made to operate over the complete pump curve, not just one specific duty point. This means that the pump can be used in numerous applications within its range, instead of being "one pump - one application".





This is what makes our slurry pumps unique

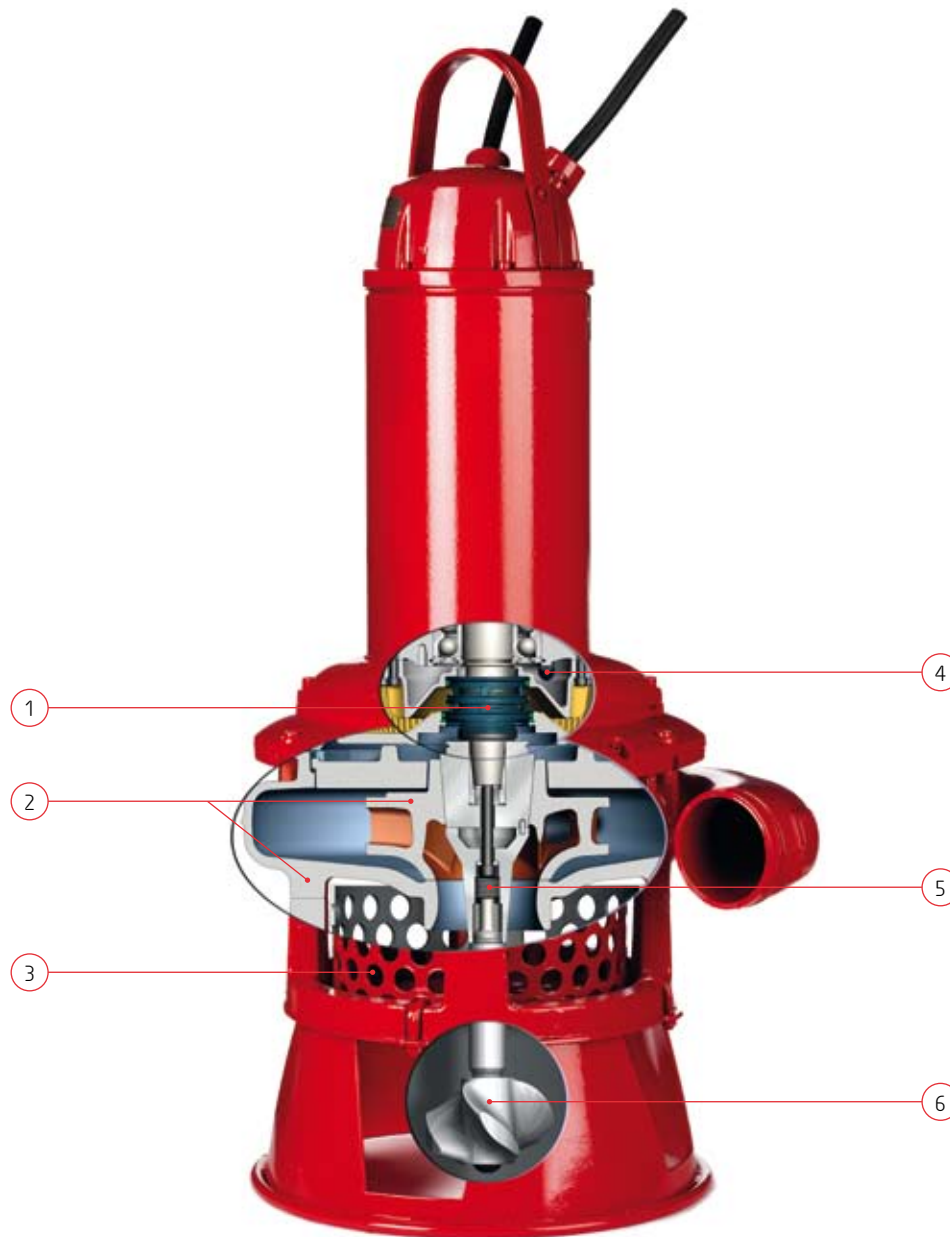

Bravo 400 - Bravo 900

1. Cartridge seal

Pre-assembled, faster and easier to mount

2 Impeller and pump housing made of Hard-iron™

Gives high wear resistance

3 Large throughlet

Handles solids of varying sizes

4 Leakage sensor

For early detection of any leakage

5 Single adjustment screw

Easy to adjust the impeller for optimal performance

6 Agitator for coarser slurries

Stirs up and pumps sand, sludge and solids in suspension



Typical Bravo applications

- Sand and Gravel
- Bentonite
- Coal and ore slurries
- Coal run off sumps
- Coal conveyor sumps
- Abrasive sludge
- Fluids with other abrasive solids
- Drill cuttings
- Mill scale
- Slag pits
- Fly ash / Bottom ash
- Taconite fines
- Tailing ponds
- Lime slurry
- Sludge tanks / ponds
- Ethanol plant mill and wash down sumps
- Ethanol plant rain and storm water removal
- Dredging
- Grit removal in sewage treatments plants
- Nuisance slurry removal
- Secondary processes in other industries that require pumps with very high durability

Technical data

Pump type

Electrical submersible slurry pump

Classification

Protection class: IP 68

Max. submersion depth: 66 ft (20 m)

Power cable

SUBCAB® AWG, 50 ft (16 m)

Discharge connection

Hose or threaded (Bravo 200 – 300)

Victaulic® (Bravo 400 – 900)

Material

Drive unit: Cast iron

Suction cover (Bravo 200 – 300): Nitrile rubber

Pump housing (Bravo 200 – 300): Cast iron

Pump housing (Bravo 400 – 900): Hard-iron™

Discharge connector (Bravo 200 – 300): Cast iron

Discharge connection (Bravo 400 – 900): Hard-iron™

Impeller: Hard- Iron™

Lifting handle (Bravo 200 – 300): Galvanized steel

Lifting handle (Bravo 400 – 900): Stainless steel

Shaft: Stainless steel

Agitator: Hard- Iron™

Studs, screws and nuts: Stainless steel

O-rings: Nitrile rubber

Option

Cooling jacket (Bravo 400 – 900)

Limitations

Max. submersion depth: 66 ft (20 m)

Max. liquid temperature: 104 °F (40 °C)

Allowed pH range: 5.5 – 14

Specifications can be changed without notice



SLURRY PUMPS: BRAVO 200 - BRAVO 300 - BRAVO 400

BRAVO 200

Technical data

Discharge connection	4"
Rated output	7.5 hp
Max power consumption	6.7 kW
Shaft speed	1740 RPM
Rated current at 230 V	19 A
Rated current at 460 V	9.6 A
Rated current at 575V	7.8 A
Throughlet	2" (50 mm)

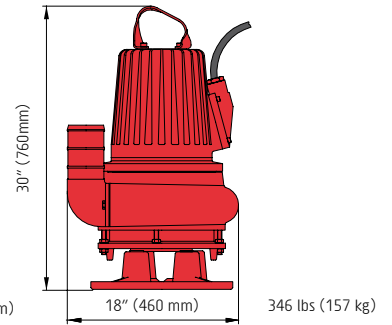
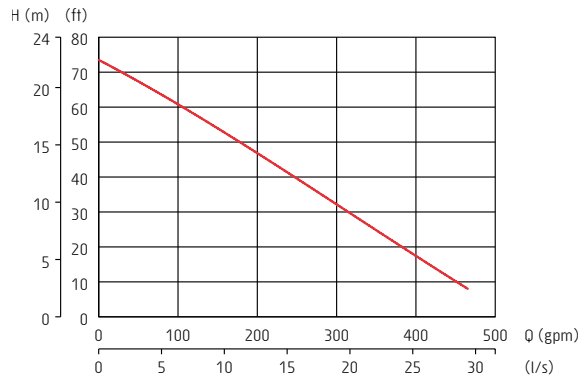

BRAVO 300

Technical data

Discharge connection	4"
Rated output	10 hp
Max power consumption	8.9 kW
Shaft speed	1735 RPM
Rated current at 230 V	25 A
Rated current at 460 V	13 A
Rated current at 575V	10 A
Throughlet	2" (50 mm)

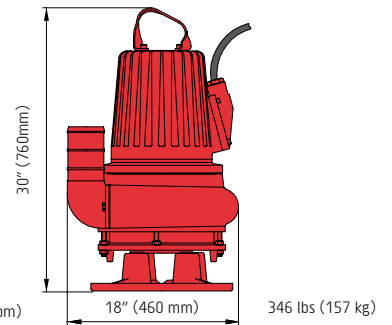
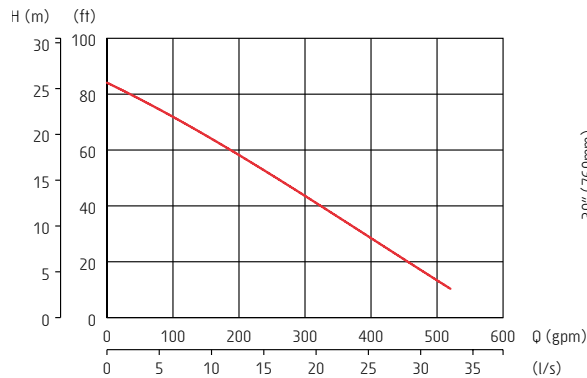

BRAVO 400

Technical data

Discharge connection	4"
Rated output	20 hp
Max power consumption	17 kW
Shaft speed	1755 RPM
Rated current at 230 V	52 A
Rated current at 460 V	26 A
Rated current at 575V	21 A
Throughlet	1 3/16" (30 mm)

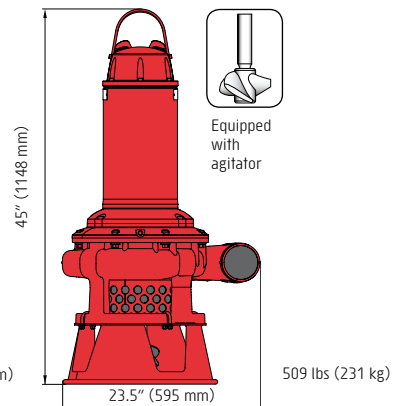
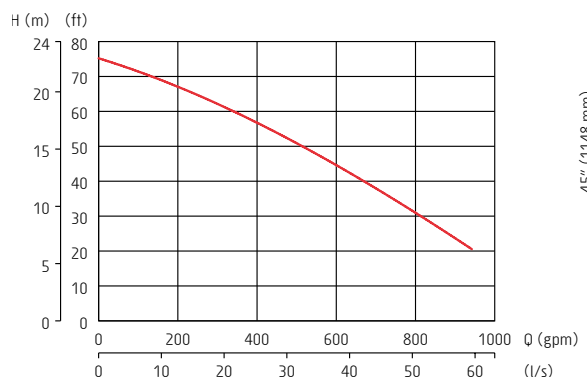

SLURRY PUMPS: BRAVO 500 - BRAVO 600 - BRAVO 700

BRAVO 500

Technical data	
Discharge connection	4"
Rated output	25 hp
Max power consumption	21 kW
Shaft speed	1755 RPM
Rated current at 230 V	61 A
Rated current at 460 V	30 A
Rated current at 575V	25 A
Throughlet	1 9/16" (40 mm)

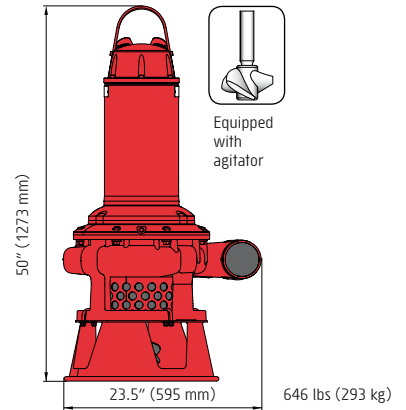
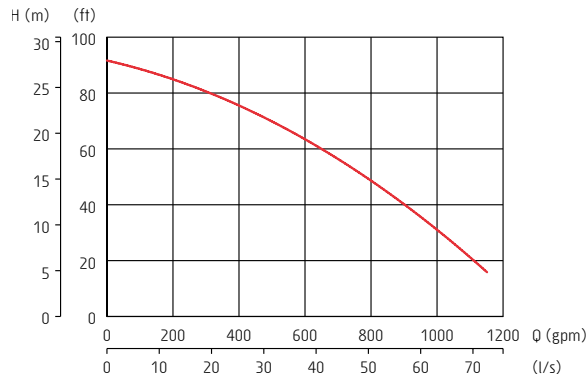

BRAVO 600

Technical data	
Discharge connection	4"
Rated output	34 hp
Max power consumption	28 kW
Shaft speed	1760 RPM
Rated current at 230 V	81 A
Rated current at 460 V	40 A
Rated current at 575V	32 A
Throughlet	1 9/16" (40 mm)

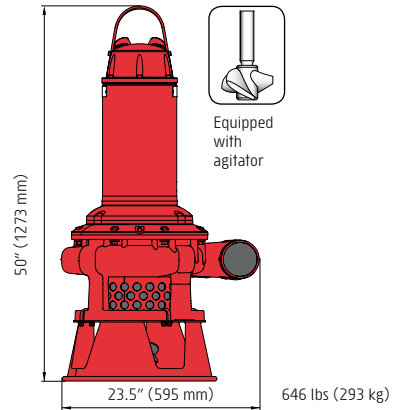
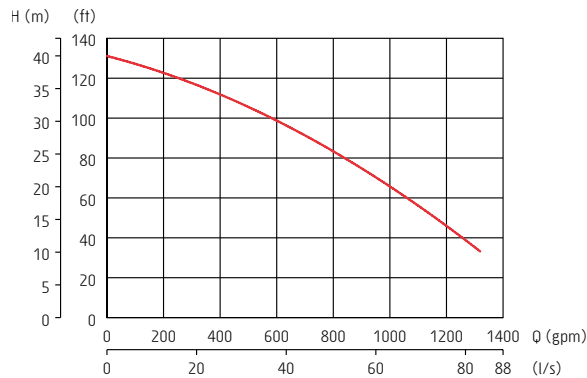

BRAVO 700

Technical data	
Discharge connection	6"
Rated output	60 hp
Max power consumption	49 kW
Shaft speed	1775 RPM
Rated current at 230 V	137 A
Rated current at 460 V	69 A
Rated current at 575V	55 A
Throughlet	1 7/16" (36 mm)

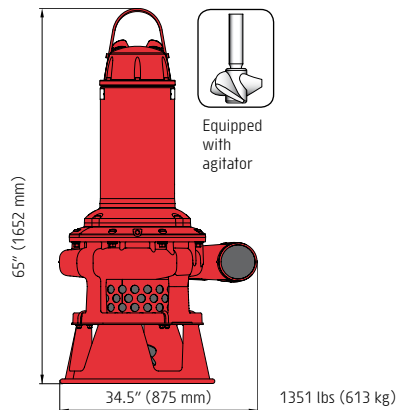
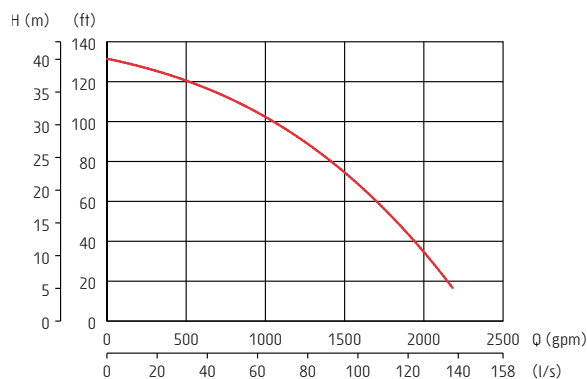

SLURRY PUMPS: BRAVO 800 – BRAVO 900

BRAVO 800

Technical data	
Discharge connection	6"
Rated output	70 hp
Max power consumption	56 kW
Shaft speed	1775 RPM
Rated current at 460 V	80 A
Rated current at 575V	63 A
Throughlet	1 7/16" (36 mm)

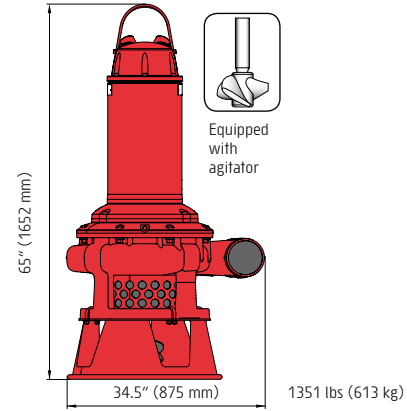
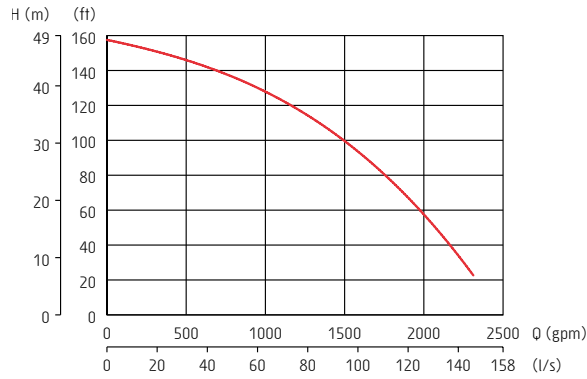

BRAVO 900

Technical data	
Discharge connection	6"
Rated output	105 hp
Max power consumption	84 kW
Shaft speed	1775 RPM
Rated current at 460 V	125 A
Rated current at 575V	101 A
Throughlet	1 7/16" (36 mm)

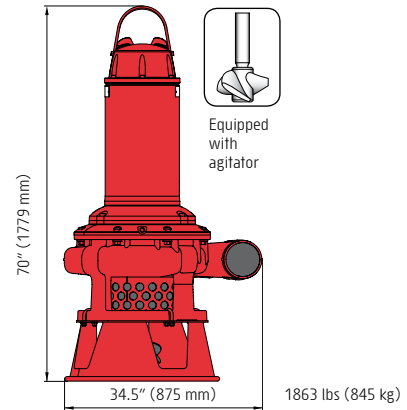
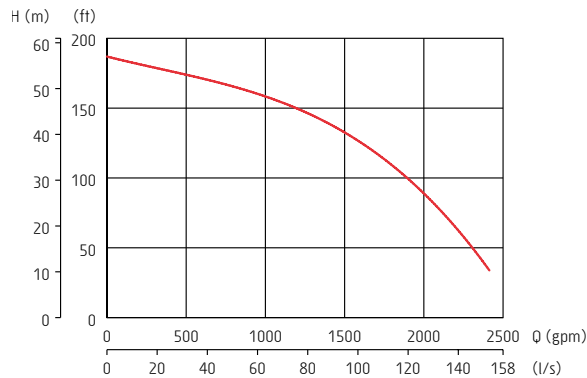



The Grindex team.

For some 50 years, Grindex has specialized in designing and manufacturing electrical submersible pumps for professionals. Durable and dependable, they are used in the most demanding and specialized applications worldwide. We have delivered over 300,000 pumps in more than 100 countries.

We offer pumps for almost any application. Our range includes drainage pumps, sludge pumps, slurry pumps and stainless steel pumps.

When you are running a Grindex pump, you can rest assured that a dedicated team is watching your back. Our experts are always there to see to your every need. Through our global network of sales and service centers, we provide the best level of support possible – day and night, seven days a week.

It's all part of the service.

For more information, please visit www.grindex.com/us