

hibon

Multistage Centrifugal Blowers



Multistage Centrifugal Blowers

In order to meet all the requirements for air and gas applications, Ingersoll Rand provides a new generation of Hibon Multistage Centrifugal Blowers: a complementary solution to rotary lobe blowers and turbo compressors for users of vacuum and low pressure systems.

With the addition of this new state-of-the-art technology, is a wide range of efficient solutions, all complying with the various operation requirements of each particular application. Multistage blowers are ideally suited for all operations where a variable flow at constant pressure is a definite requirement. The performance characteristics of these blowers generate a variable flow and power at a constant speed.

Operating Principle

Blowers are dynamic radial compressors. They build up a pressure by accelerating the fluid in a set of impellers and then decelerating the fluid by means of long-radius and high-efficiency diffusers.

By activating a valve located on the suction side, Hibon blowers' special design allows for modulation of airflow while maintaining a constant pressure. The power consumption is thus in direct proportion to the required mass flow rate.

Benefits

Ingersoll Rand offers the benefits of the proper equipment solution that is economical and quiet.

Hibon's flow versus pressure characteristic curve allows for a wide operating range down to 50% of flow rate, without surging.

Ingersoll Rand's knowledgeable staff and our local manufacturers representatives are a valuable asset to every project.



Applications

Designed to handle air or gas, Hibon blowers are used in the following applications:

- water treatment
- waste water treatment
- combustion air
- central vacuum cleaning
- fluidization and homogenization of silos
- liquids or baths aeration and agitation
- air knife drying
- galvanizing process
- gas compression for chemical and petro-chemical industries
- pulp and paper, printing industries

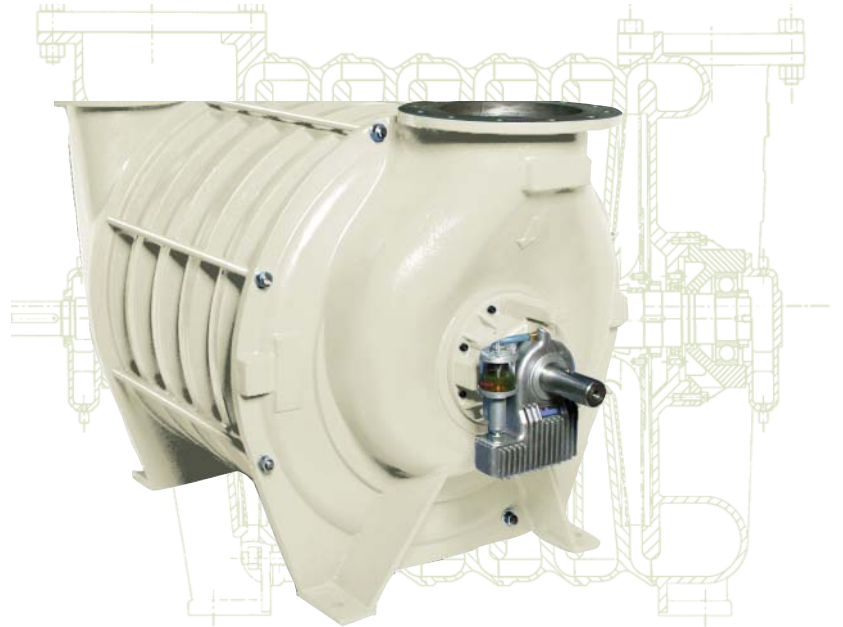



Construction and benefits

Hibon blowers are fabricated using the most advanced processes, with digital control machining for the highest precision level. Each unit is tested and a report is issued showing vibration data.

Specific design features:

- Blower inlet/outlet heads and intermediate sections are fabricated of cast iron ASTM A 48-30B (FGL 200) for an outstanding strength.
 - Impellers are of cast or riveted aluminium alloy, depending on the flow characteristics required. They are statically and dynamically balanced for efficient operation without vibration.
 - There are ample internal clearances, with no interference fitting surfaces, offering spark-free operation.
 - Shaft is SAE 10-45 (XC 38) steel.
 - Type C3 ball bearings are designed for 100,000 hours, AFBMA-B10 (NF ISO 281 LH10) service life. They are oil bath lubricated, by means of an advanced design factory preset lubricator, which assures a constant oil level for long service life.
 - Bearing housings are fabricated of ASTM A 48-38B (FGL 200) cast iron, temperature-stabilized and precision-machined to ensure parallel alignment to the casing.
- Additionally, the housing is designed to prevent pressurization from the process air, thus eliminating any potential oil leaks.
- Carbon ring seals within the bearing housing reduce air leaks while improving compression efficiency.
 - Compressed air/gas is guaranteed 100% oil free.

Construction features

High Efficiency
Cast iron ASTM A 48-30B
Large inlet guide vane on series 450 and above

High Efficiency
Large turning radius of interstage channel

Low Vibration
Cast aluminum or fabricated impellers statically and dynamically balanced

Long Life
Constant level oiler

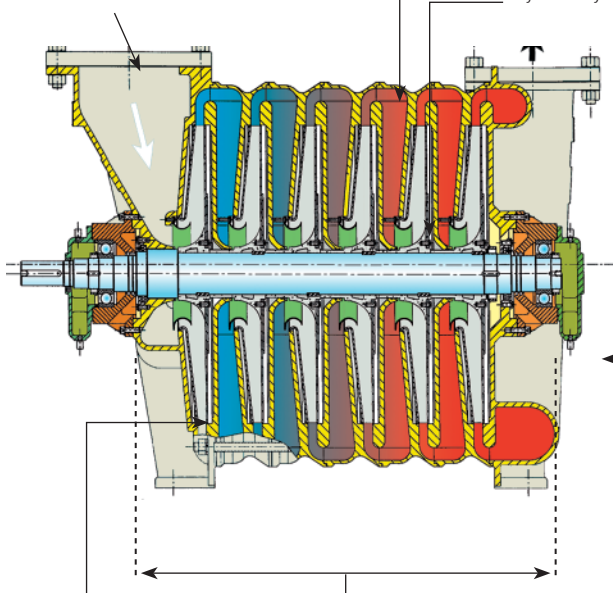

High Efficiency
Optimized ratios of impellers vs. diffuser diameter

Low Vibration
Minimum bearing span

Long Life
Non-pressurized outboard bearing housing (no oil leakage)

High Efficiency
Carbon ring seals (double carbon ring with purge upon request)

Heavy Duty
Ball-type bearings rated at 100,000 hours

Easy Maintenance
Outboard housing bearings

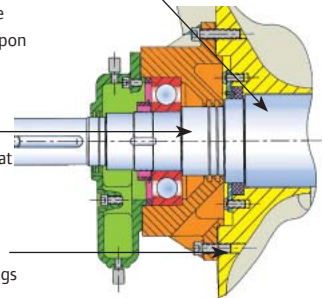

Typical Installation

- | | |
|----------------------------|----------------------------------|
| 1 Centrifugal blower | 9 Threaded flange |
| 2 Diff. pressure indicator | 10 Motor |
| 3 Inlet silencer | 11 Temperature indicator |
| 4 Inlet valve | 12 Surge by-pass valve motorized |
| 5 Flexible sleeve (inlet) | 13 Surge by-pass silencer |
| 6 Flexible sleeve (outlet) | 14 Inlet filter |
| 7 Check valve | 15 Isolating valve |
| 8 Pressure gauge | |

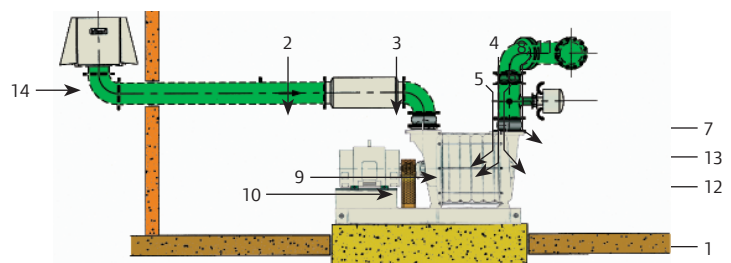

State of the Art Control Systems

Ingersoll Rand is an ISO 9001 certified company, quality-oriented throughout its operations, including its employees' qualifications and production performance. Blowers are selected on the basis of characteristic curves that are validated on an automated ASME certified test bench. Curves are established utilizing the same software as used in aeronautics for airflow in aircraft turbines.

Process and Instrumentation Diagram

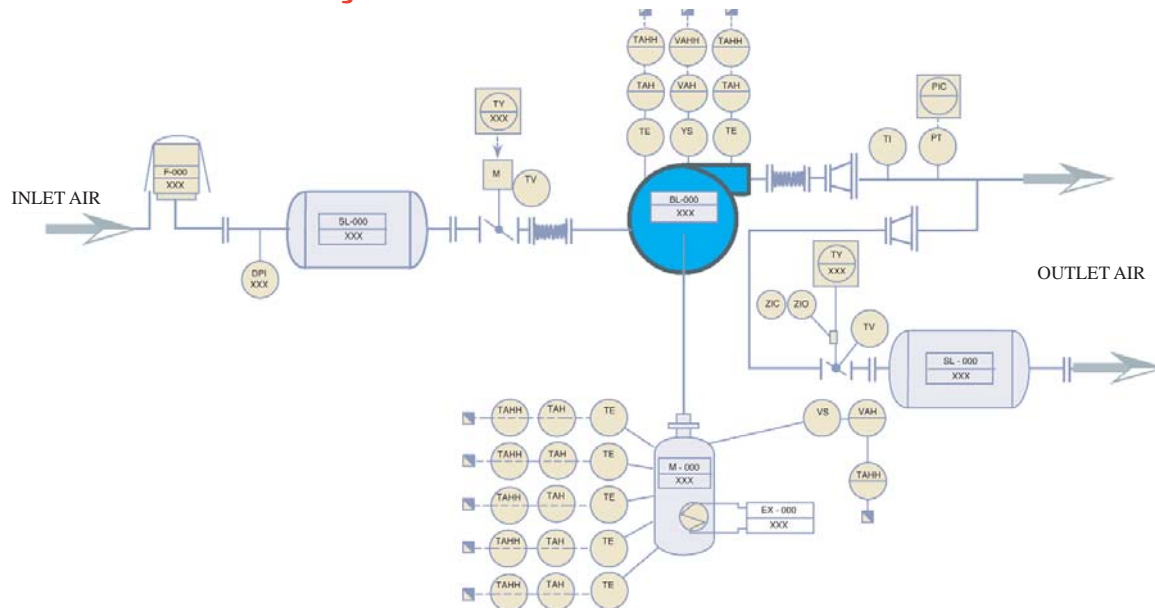

Control System

The functional design of each unit allows it to be equipped with a control panel using a programmable logic controller with an operator interface for a highly user-friendly operation. This control panel will accept inputs from instrumentation, such as RTD sensors, vibration switches, dissolved oxygen meters, and pressure transmitters.

In addition, the control panel monitors start/stop sequences. It allows for programming to

automatically maintain constant air and gas flow rate, based on data from the operator or an external signal from the process controllers such as dissolved oxygen, pressure and temperature sensors.

A programmable controller is used with components that are commercially available.

This controller operates with Hibon software, optimized and adapted for each particular application.

Packaging Options

Available Equipment Options:

- Corrosion-resistant coatings for casing and impeller.
- Variable Frequency Drive packages complete with Controls.

Range

Hibon blowers meet the most demanding industrial/municipal requirements for vibration, noise and efficiency. Hibon blowers can deliver 500 CFM to 25,000 CFM of dry/clean air without fluctuations, at pressures up to 20 psig (1.3 bar) and a vacuum up to 15 inches of mercury (500 mbar absolute).

Multistage Centrifugal Blower Flow and Pressure Range

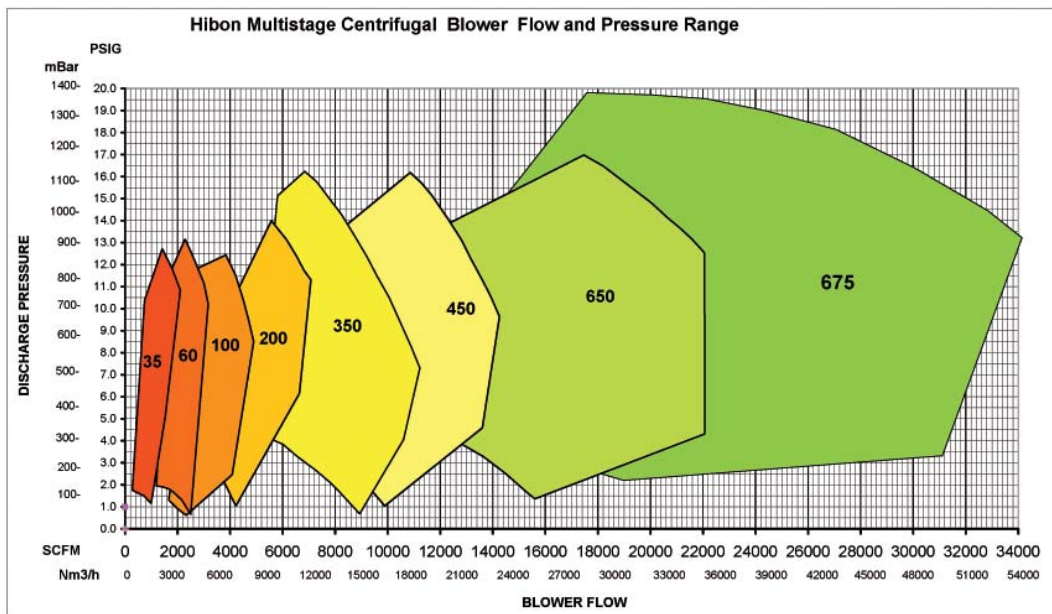

Unit Assembly

Blower assembly is specifically designed to provide a compact and complete unit, with special attention to alignment of the motor/blower base assembly, for a vibration-free solution.

Many accessories are available to suit environmental and operating requirements, such as an inlet filter/silencer, a modulating inlet/discharge valve, flexible couplings, and check valves.

No special foundation or anchors are required for the unit, allowing it to advantageously replace any existing installation with a minimum of modifications.

Unit with gearbox





Ingersoll Rand Industrial Technologies provides products, services and solutions that enhance our customers' energy efficiency, productivity and operations. Our diverse and innovative products range from complete compressed air systems, tools and pumps to material and fluid handling systems and environmentally friendly microturbines. We also enhance productivity through solutions created by Club Car®, the global leader in golf and utility vehicles for businesses and individuals.

www.ingersollrand.com

www.hibon.com

Low Pressure Business Unit / Air Solutions

Ingersoll Rand Industrial Technologies
2, avenue Jean Paul Sartre
59290 Wasquehal
France

Tel: +33 (0) 3 20 45 39 39

Fax: +33 (0) 3 20 45 39 97

* Consult www.hibon.com for further contact information.

Low Pressure Business Unit / Air Solutions

Ingersoll Rand Industrial Technologies
12055, Cote de Liesse
Dorval, Quebec
Canada, H9P 1B4

Tel: +1 514 631-3501

Fax: +1 514 631-3502

Ingersoll Rand compressors are not designed, intended or approved for breathing air applications. Ingersoll Rand does not approve specialized equipment for breathing air application and assumes no responsibility or liability for compressors used for breathing air service.

Nothing contained on these pages is intended to extend any warranty or representation, expressed or implied, regarding the product described herein. Any such warranties or other terms and conditions of sale of products shall be in accordance with Ingersoll Rand's standard terms and conditions of sale for such products, which are available upon request.

Product improvement is a continuing goal at Ingersoll Rand. Designs and specifications are subject to change without notice or obligation.